

SERIES 1450 TERRACE OUT-SWING DOOR

TEST SIZE W x H	AAMA RATING	AIR INFILTRATION	DESIGN PRESSURE	WATER RESISTANCE	U-VALUE	SHGC	VT
48" x 96"	AW-PG75	≤0.10 cfm/ft ²	75 psf	12 psf	0.32-0.54	0.15-0.5	0.2-0.53

TABLE OF CONTENT

- INTRODUCTION -P1
- 1450 -P2
- 1450-1 -P3
- 1450-2 -P4
- MULLION -P5-P7
- FACE FLANGE ADA SILL -P8
- 1450 ADA THRESHOLD -P9-P11
- LOCK OPTION FOR ADA -P12

FEATURES

- ALUMINUM THERMAL-BREAK TERRACE OUT-SWING DOOR
- 3-1/4" FRAME DEPTH
- 1" DOUBLE PANE INSULATED TEMPERED GLASS
- HEAVY DUTY EXTRUSION
- AAMA 2604 POWDER COAT PAINT
- OPENING LIMIT BAR
- MULTI POINT LOCK SYSTEM
- THUMB TURN INTERIOR LOCKING MECHANISM

OPTIONAL SELECTIONS

- LOW-E COATING & ARGON FILLED IGU
- 2" FACE FLANGE
- CUSTOM FINISH AND CUSTOM COLOR
- GRIDS
- 1-1/4" INSULATED GLASS
- KEY LOCK ON EXTERIOR
- ADA THRESHOLD
- 10" KICK PLATE
- HYDRAULIC DOOR CLOSER
- MINIMALIST HANDLE DESIGN

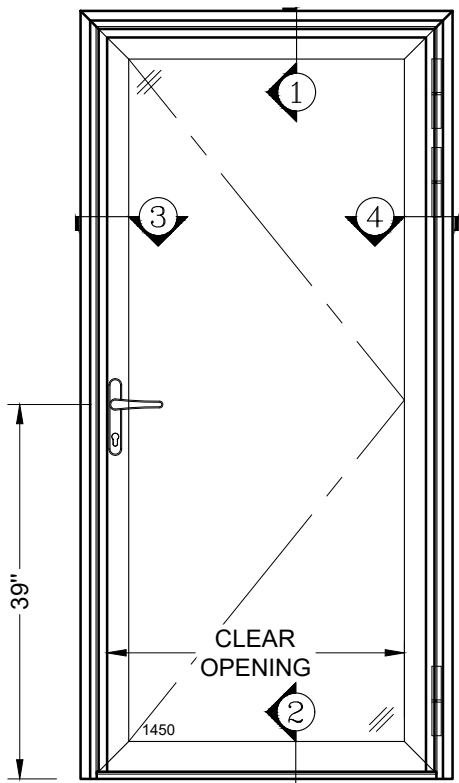

1450 OUT-SWING DOOR

(CLEAR OPENING = DOOR WIDTH - 7³/₄")

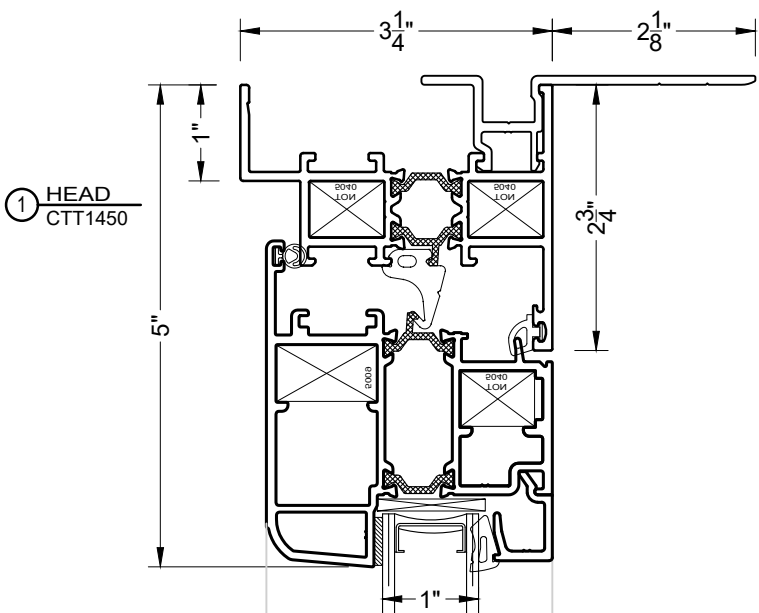

① HEAD
CTT1450

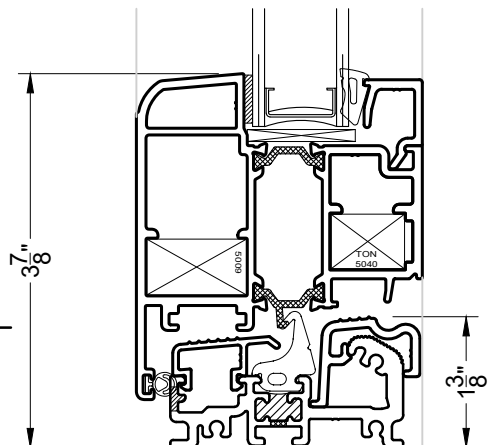

② SILL
CTT1450

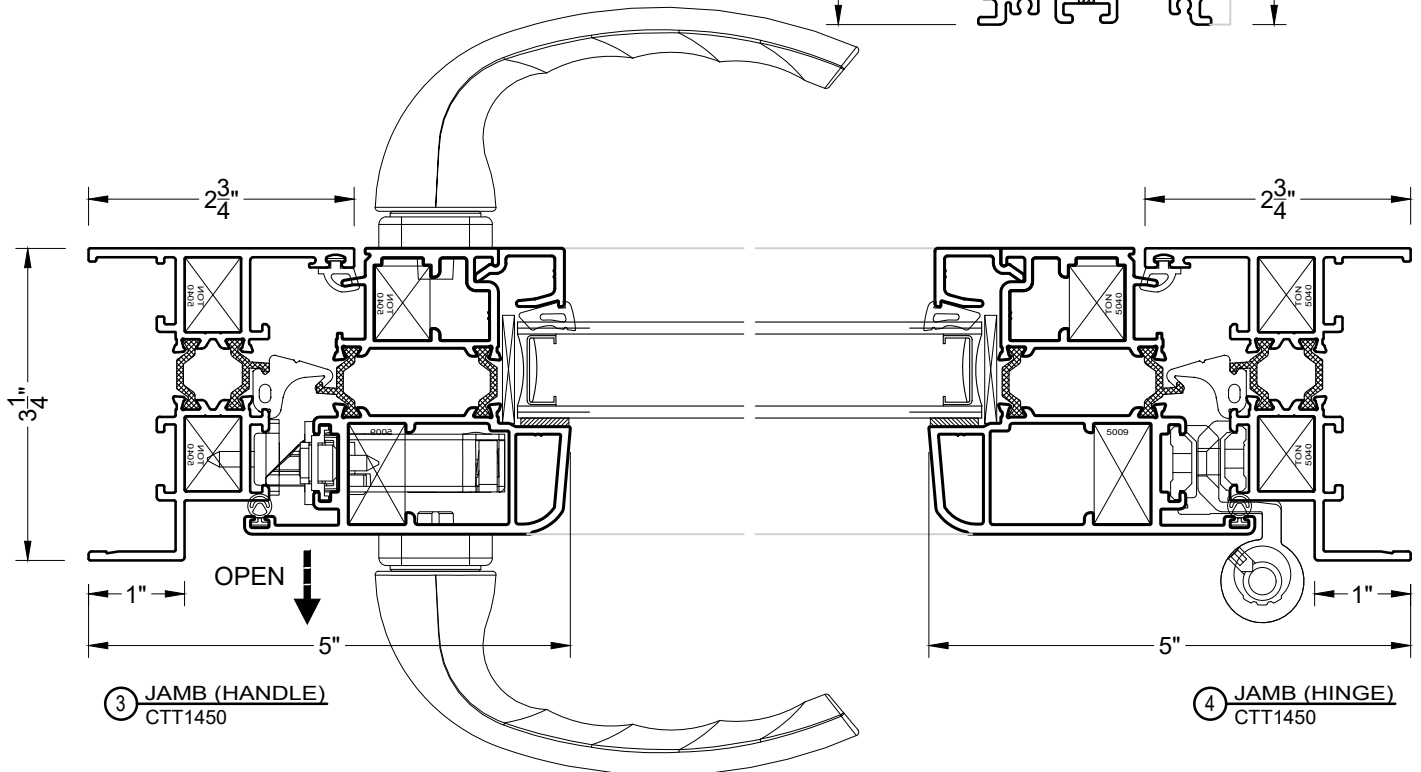

③ JAMB (HANDLE)
CTT1450

④ JAMB (HINGE)
CTT1450

VER: 2022.09

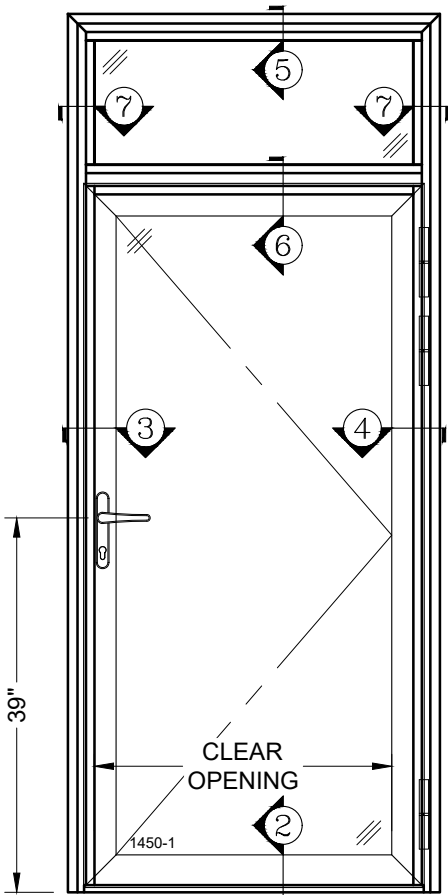

1450-1 OUT-SWING DOOR
 W/ TRANSOM

(CLEAR OPENING = DOOR WIDTH - 7³/₄")

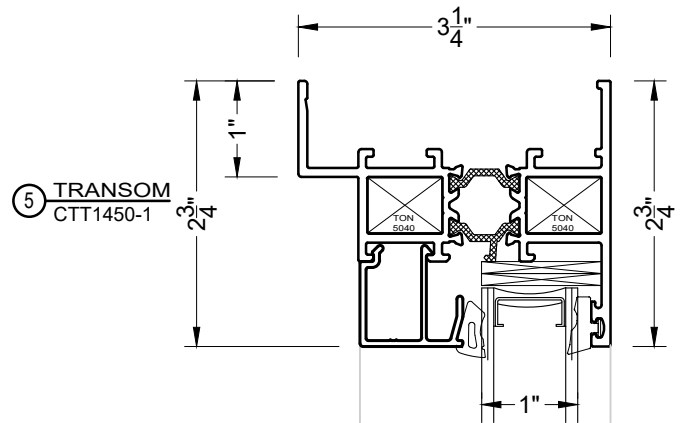

⑤ TRANSOM
 CTT1450-1

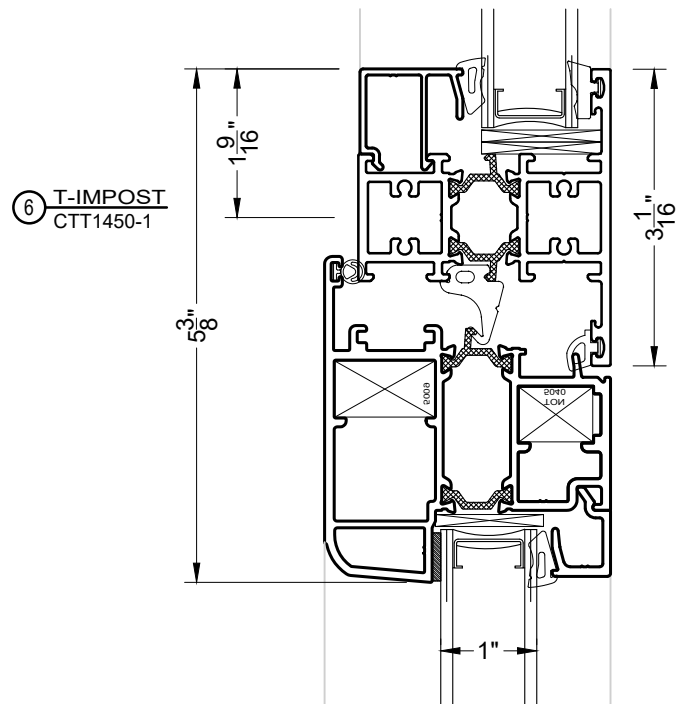

⑥ T-IMPOST
 CTT1450-1

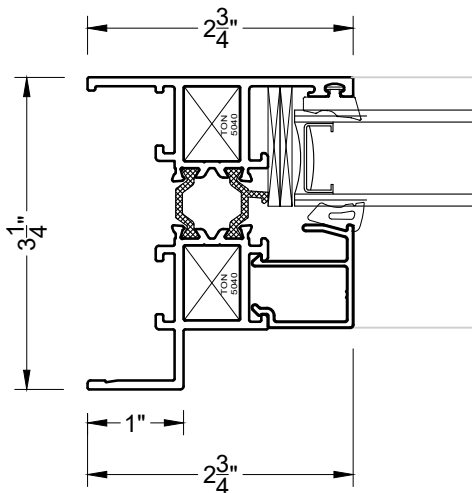

⑦ JAMB (TRANSOM)
 CTT1450-1

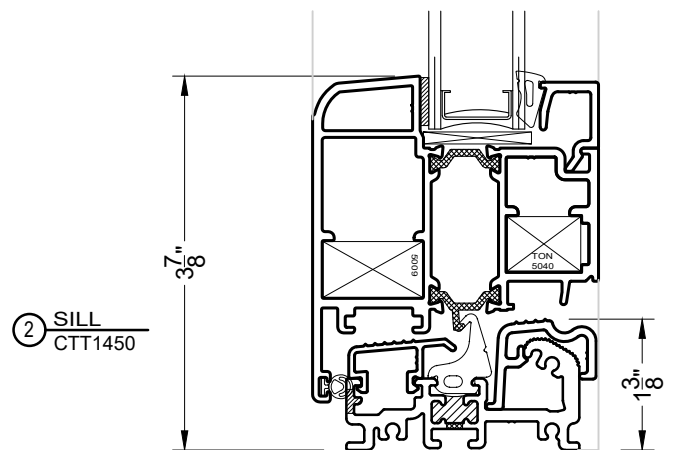

② SILL
 CTT1450

VER: 2022.09

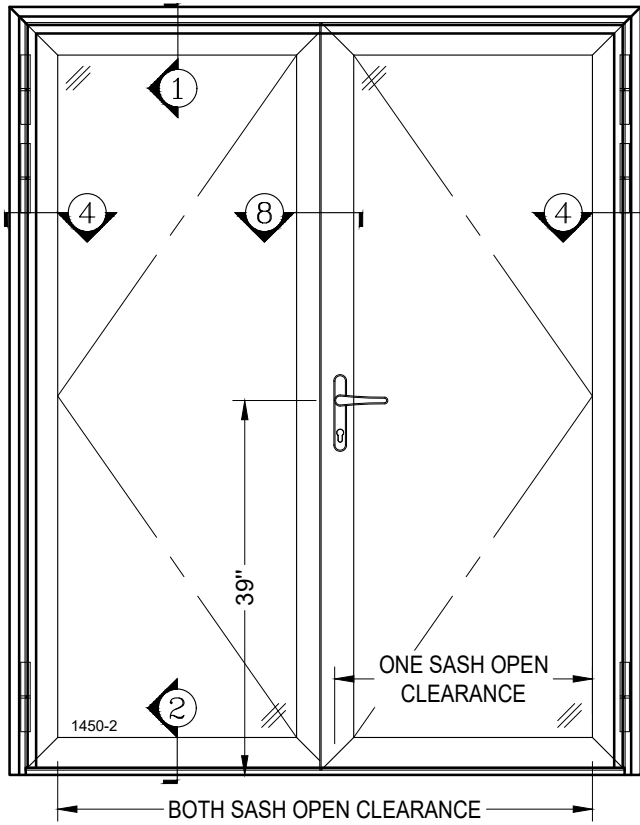

ADA SILL OR INTEGRAL TRANSOM IS NOT AVAILABLE FOR 1450-2 OUT-SWING FRENCH DOOR

1450-2 OUT-SWING FRENCH DOOR*

ONE SASH OPEN:
 (CLEAR OPENING = DOOR WIDTH / 2 - 6")

BOTH SASH OPEN:
 (CLEAR OPENING = DOOR WIDTH - 10")

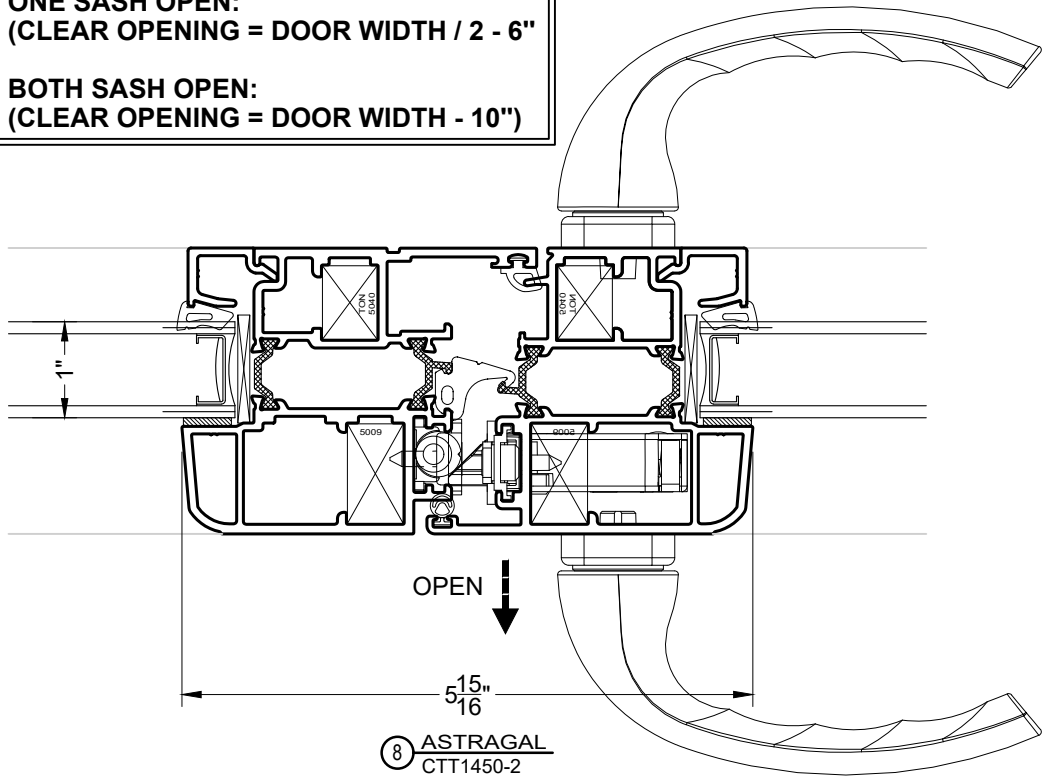

VER: 2022.09

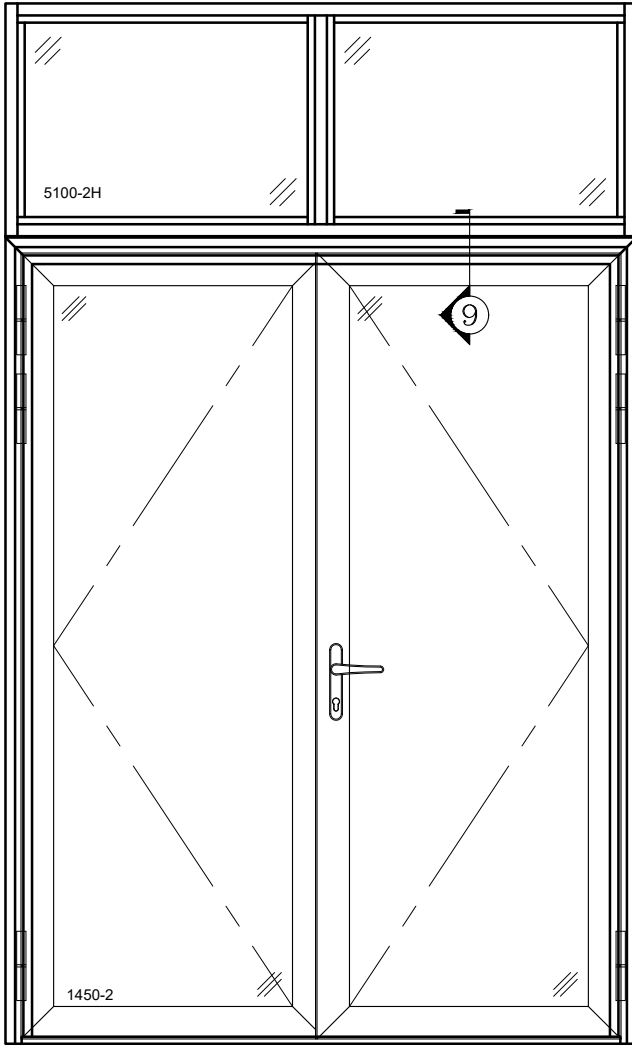

PW5100-2H TRANSOM OVER CTT1450-2
 W/ H MULLION

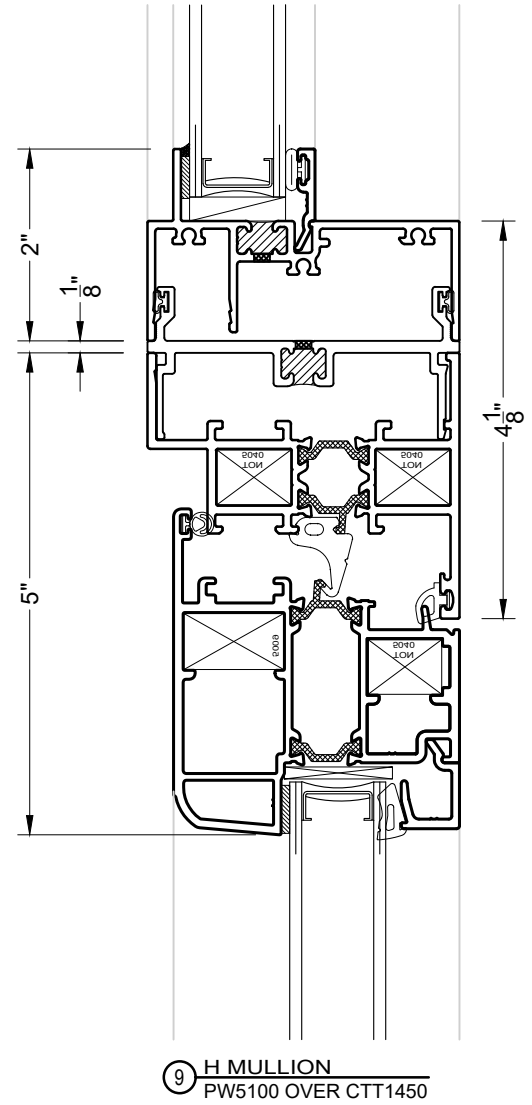

VER: 2022.09

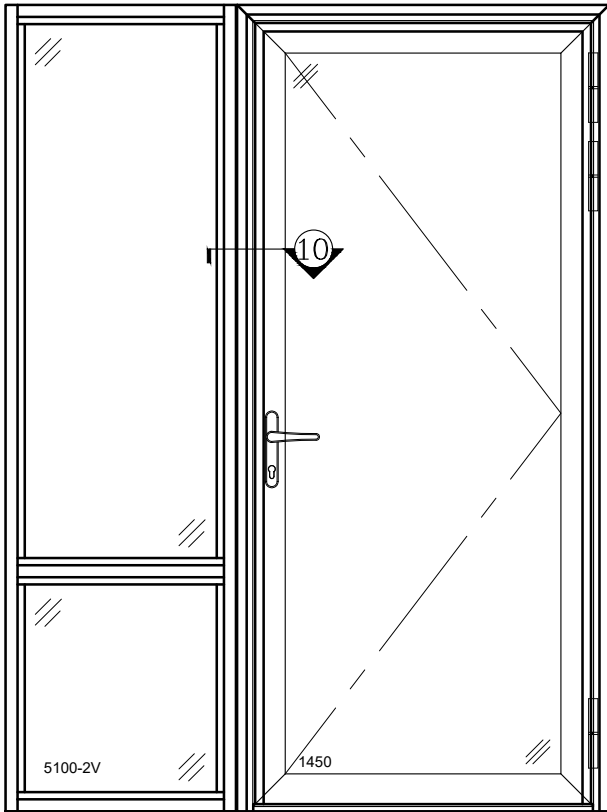

PW5100-2V SIDELITE & CTT1450
 W/ H MULLION

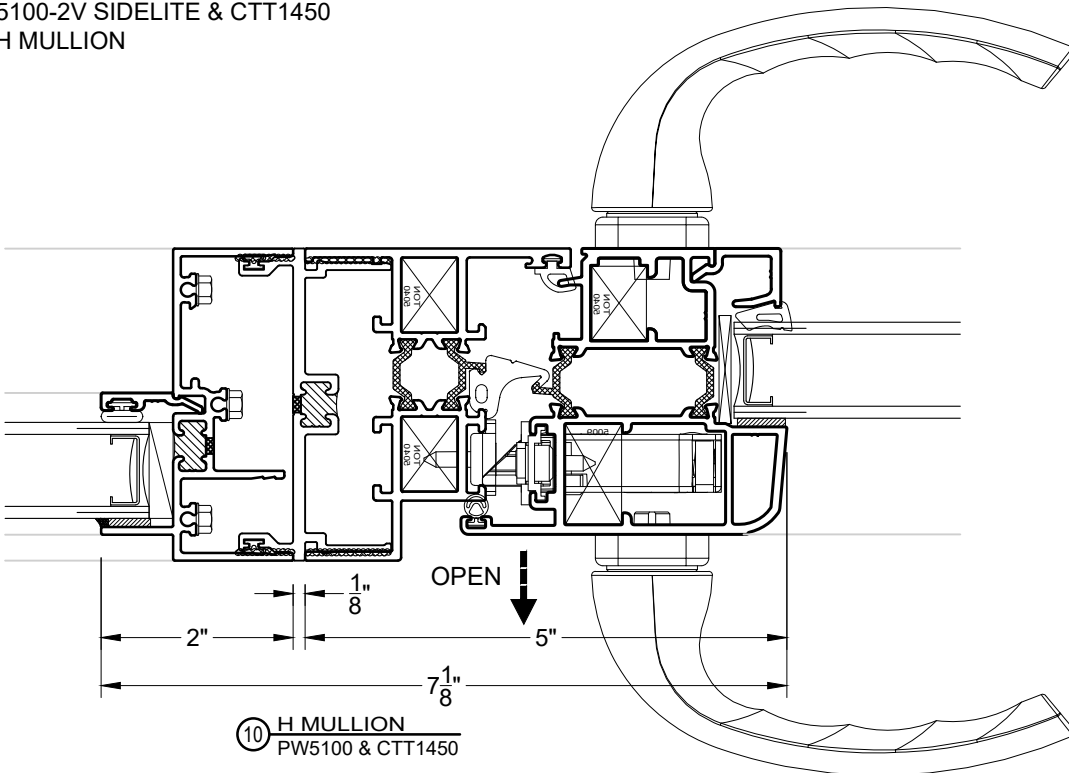

VER: 2022.09

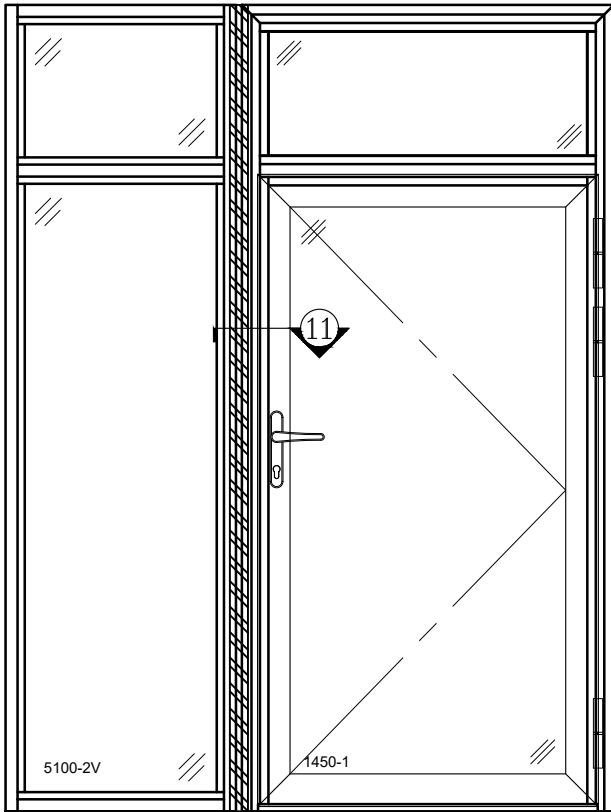

PW5100-2V SIDELITE & CTT1450-1
 W/ 3CP MULLION

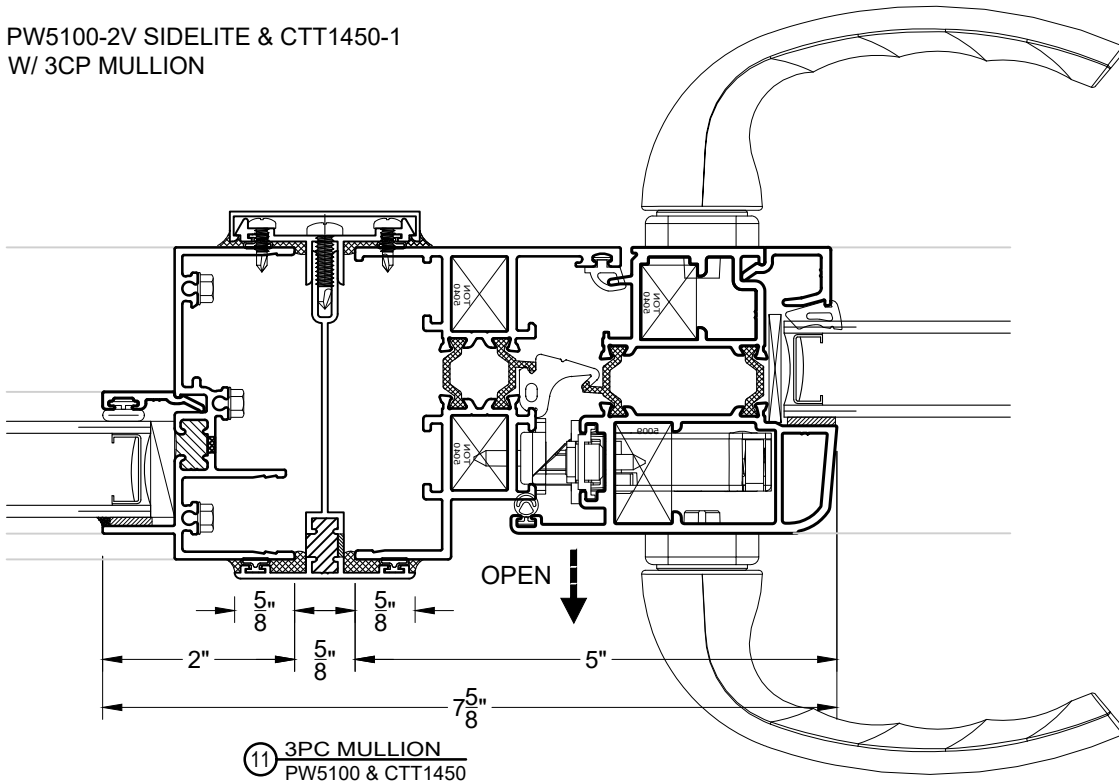

VER: 2022.09

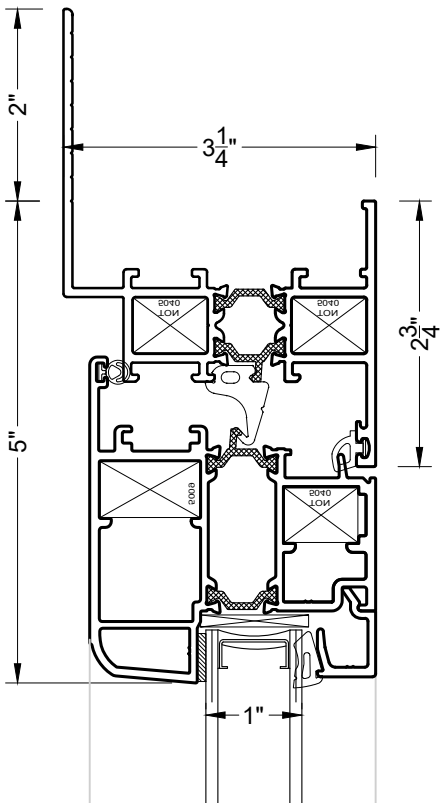

①B 2" FLANGE HEAD
 CTT1450

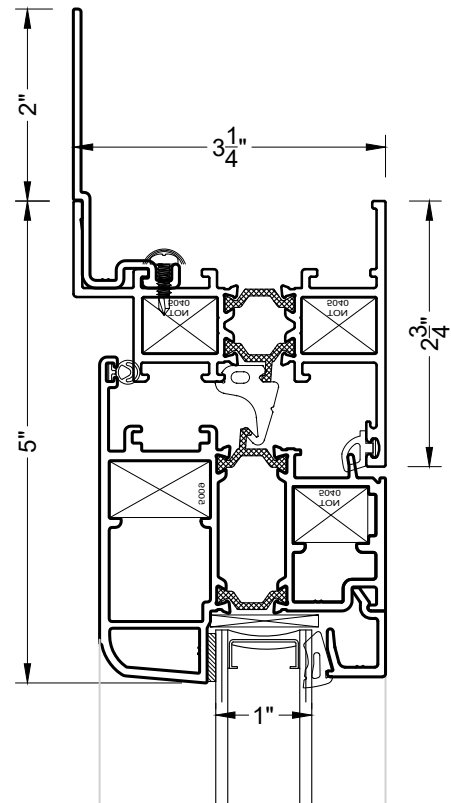

①A 2" APPLIED ON FLANGE HEAD
 CTT1450

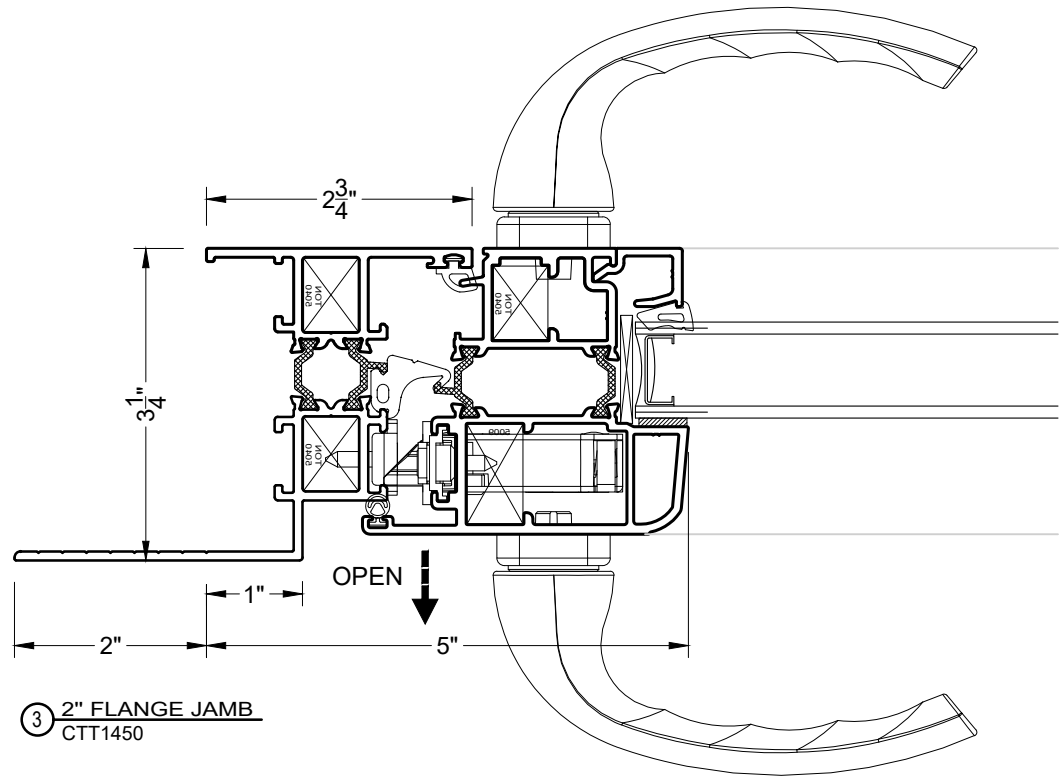

③ 2" FLANGE JAMB
 CTT1450

VER: 2022.09

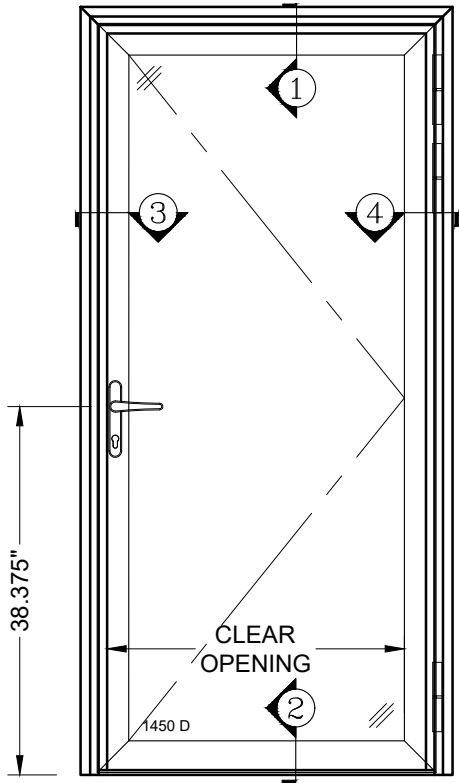

1450 OUT-SWING ADA THRESHOLD

-PLEASE CONTACT YOUR SALE REP. FOR TEST RESULT AND KICK PLATE OPTION

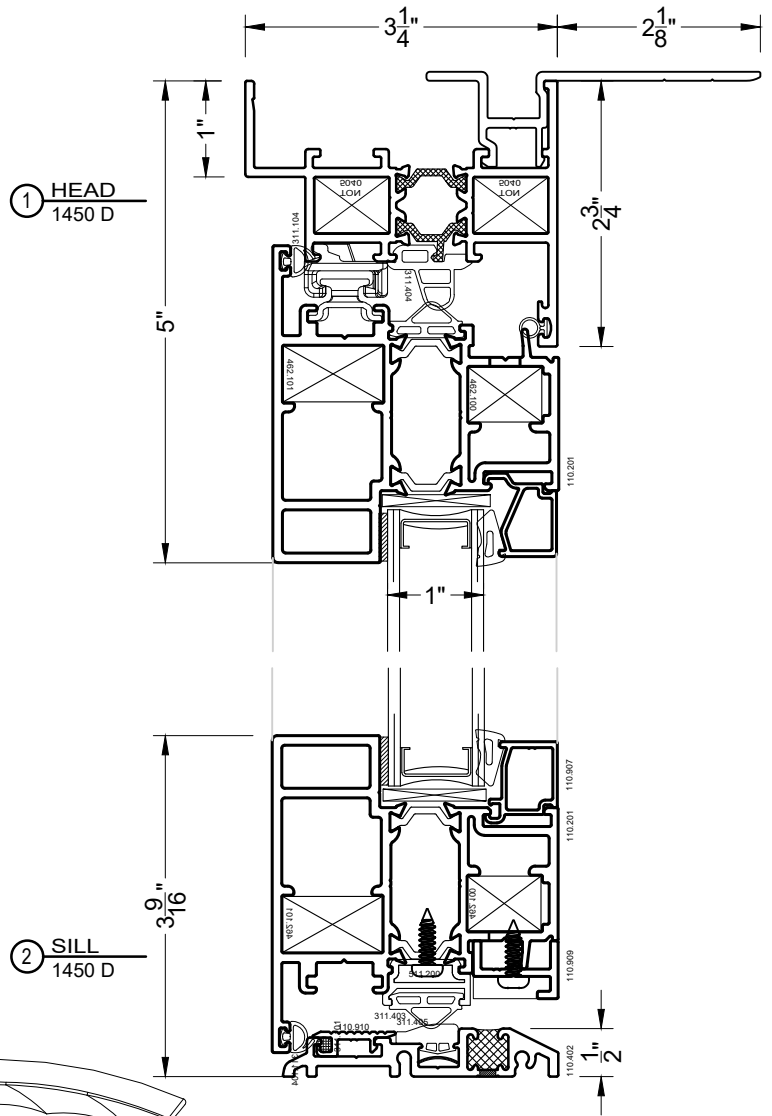

① HEAD
1450 D

② SILL
1450 D

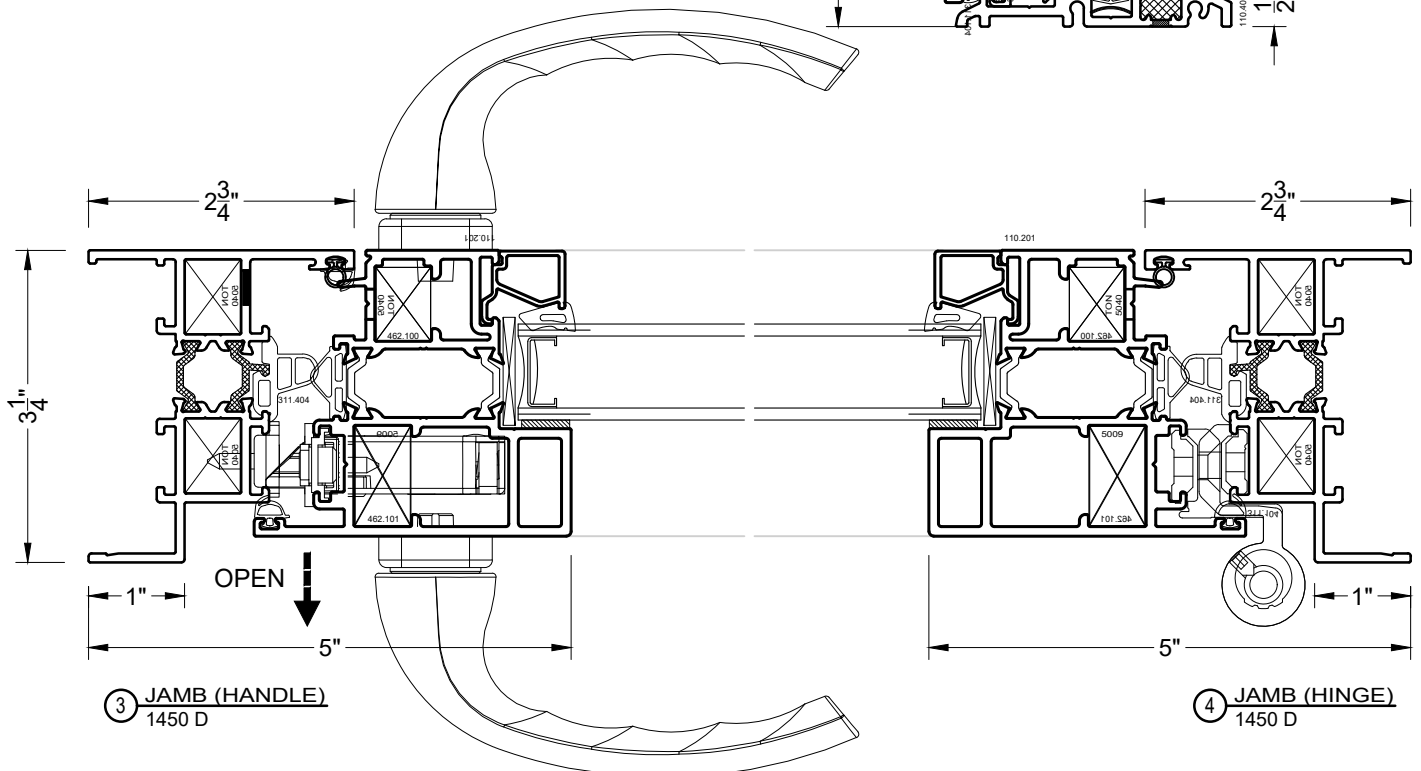

③ JAMB (HANDLE)
1450 D

④ JAMB (HINGE)
1450 D

VER: 2022.09

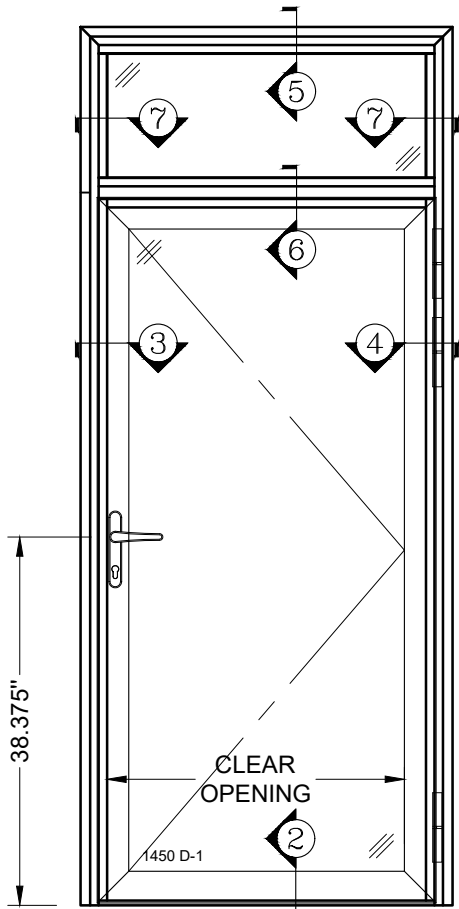

1450 OUT-SWING ADA THRESHOLD W/ TRANSOM

-PLEASE CONTACT YOUR SALE REP. FOR TEST RESULT AND KICK PLATE OPTION

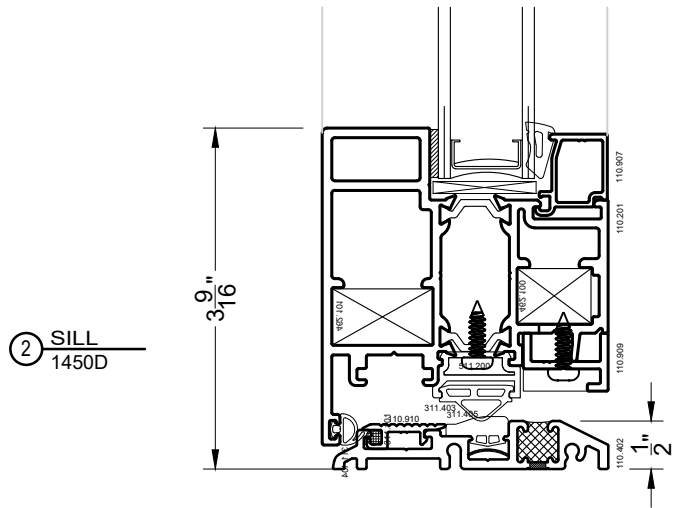
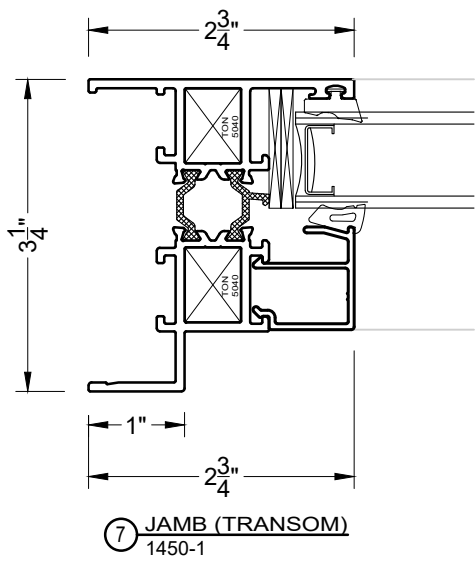
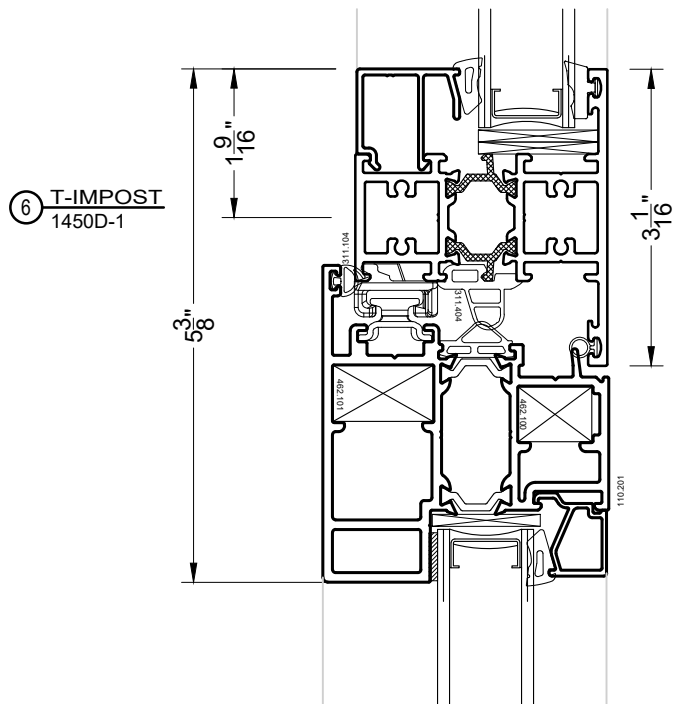
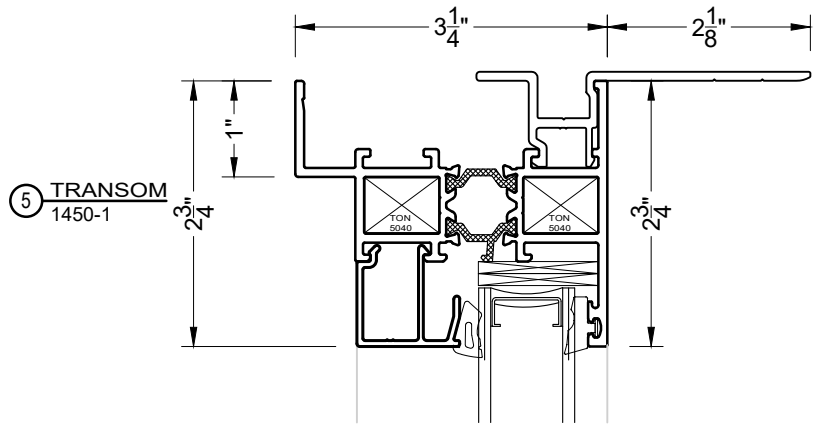

VER: 2022.09

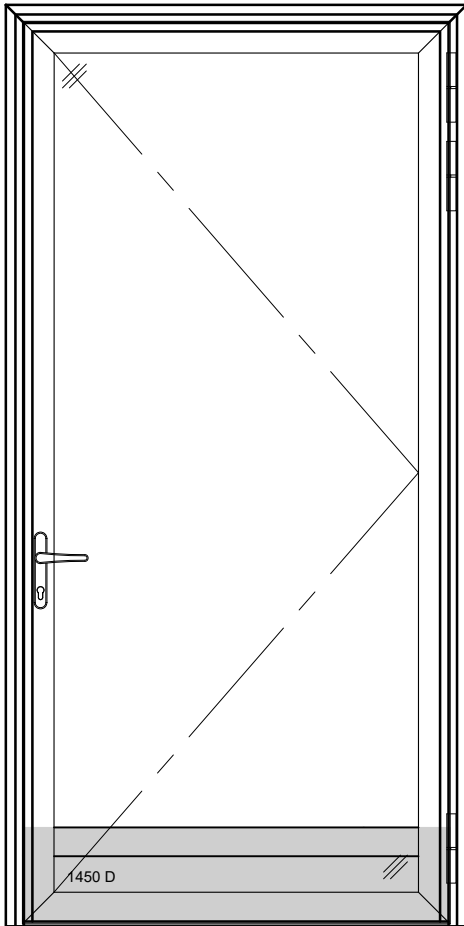

1450 OUT-SWING ADA THRESHOLD WITH 10" KICK PLATE

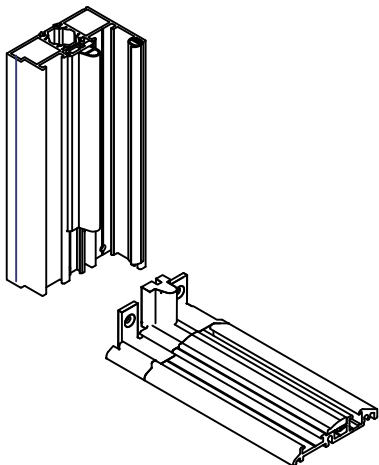
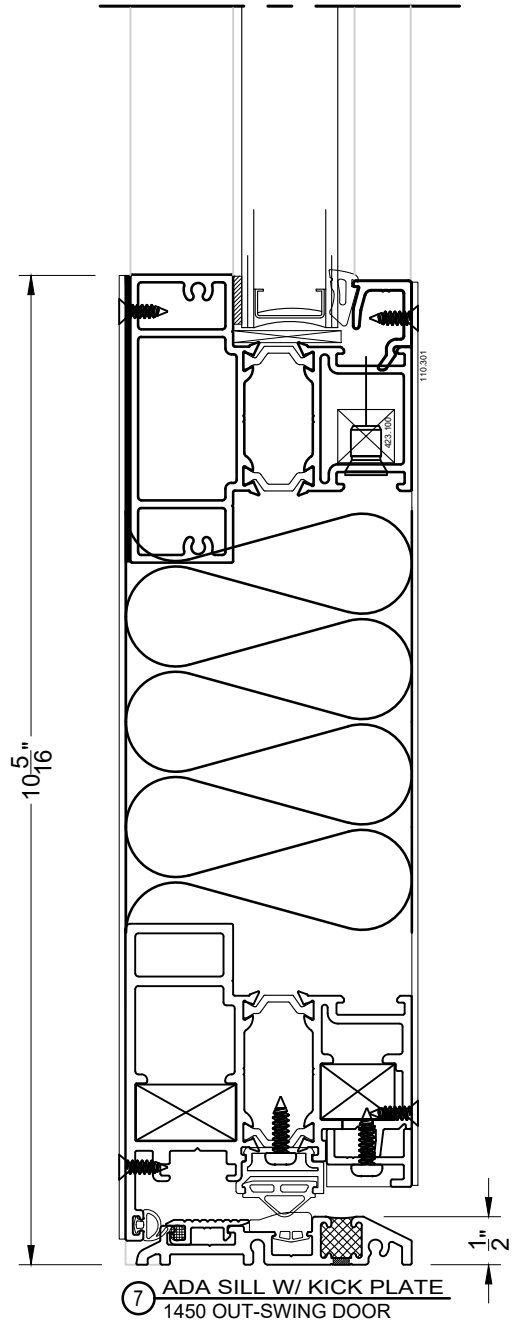

REMOVABLE THRESHOLD

VER: 2022.09

OPTIONAL HANDLE AND LOCK SET FOR
BALCONY DOOR OUTS-WING
(ADA SILL AND STANDARD SILL)

