

SERIES 200 DOUBLE HUNG WINDOW

TEST SIZE W x H	AAMA RATING	AIR INFILTRATION	DESIGN PRESSURE	WATER RESISTANCE	U-VALUE	SHGC	VT
39.5" x 63"	R-PG50	≤0.30 cfm/ft ²	50 psf	7.5 psf	0.17-0.45	0.16-0.58	0.30-0.61



TABLE OF CONTENT

- INTRODUCTION -P1
- SECTION DETAILS -P2
- MULLION -P3-P4
- ACCESSORIES -P5

FEATURES

- 3-1/4" FRAME DEPTH
- 7/8" INSULATED GLASS
- SINGLE STRENGTH GLASS
- MEETING RAIL LOCK
- DUAL VENT LOCK
- TILT SASH WITH TILT LATCH
- CONTINUOUS LIFT HANDLE ON BOTTOM SASH
- SLOPED SILL
- CONSTANT FORCE COIL BALANCE
- JAMB ADJUSTER
- DOUBLE-SEAL WEATHERSTRIPPING

OPTIONAL SELECTIONS

- LOW-E COATING & ARGON FILLED IGU
- CUSTOM FINISH AND CUSTOM COLORS
- SPIRAL OR BLOCK AND TACKLE BALANCE
- HALF OR FULL SCREEN
- LIMIT STOPS
- INSTALLATION SCREWS
- GRIDS
- OTHER OPTIONAL ACCESSORIES

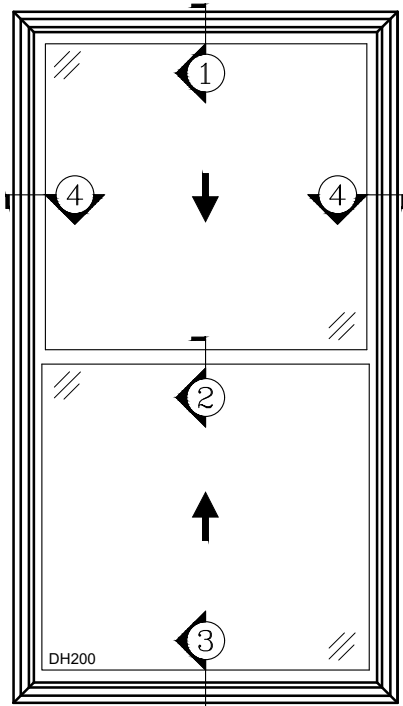

200 DOUBLE HUNG

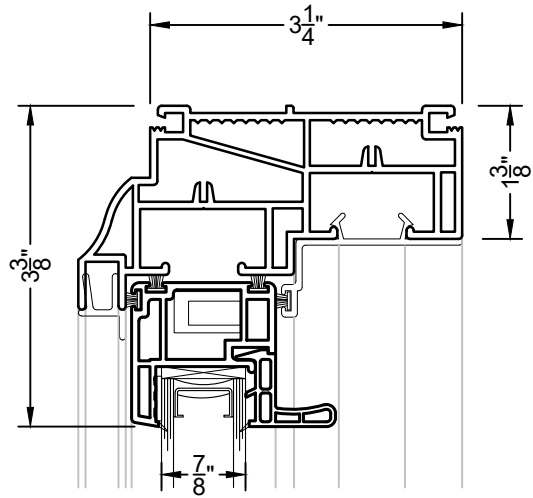

① HEAD
DH200

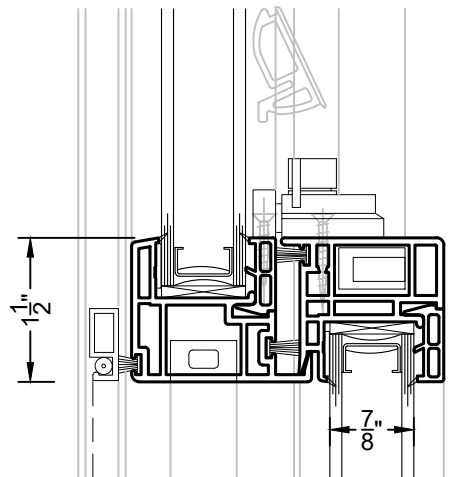

② MEETING RAIL
DH200

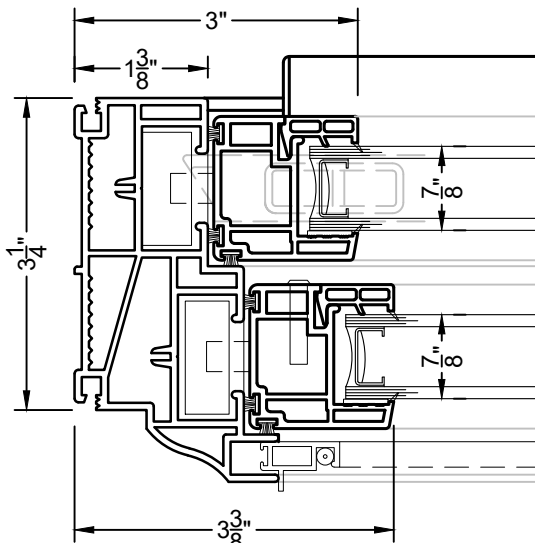

④ JAMB
DH200

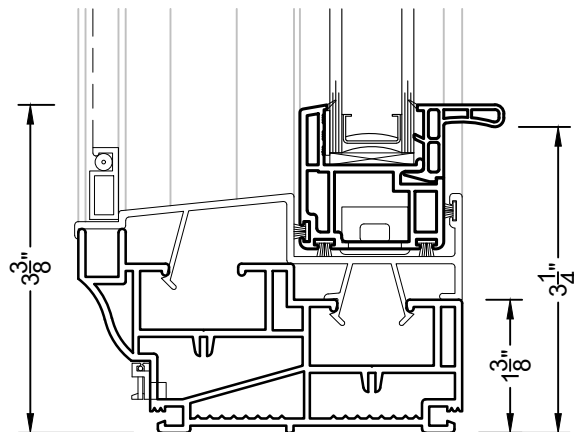

③ SILL
DH200

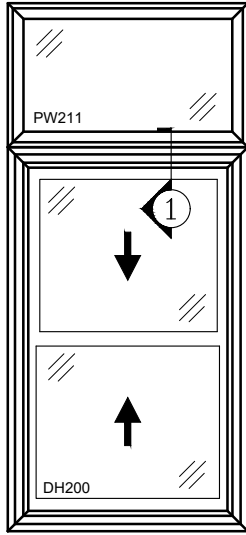

PW211 OVER DH200

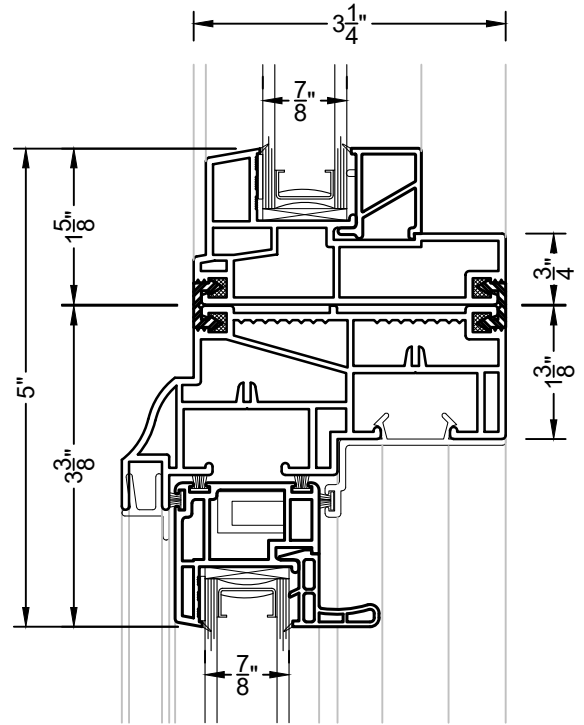

① H-MULLION
 PW211 OVER DH200

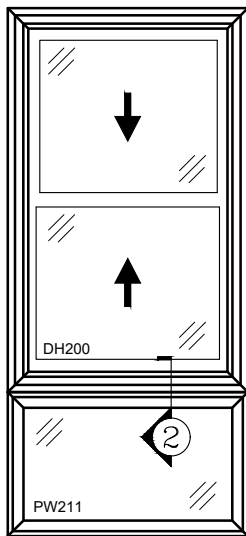

DH200 OVER PW211

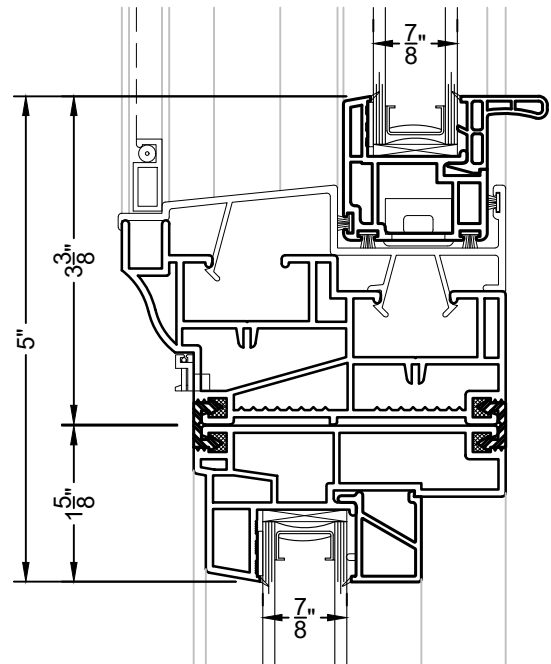

② H-MULLION
 DH200 OVER PW211

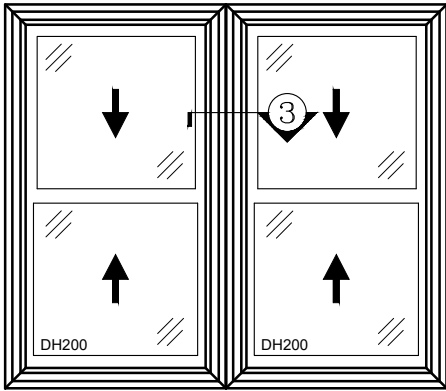

DH200 & DH200

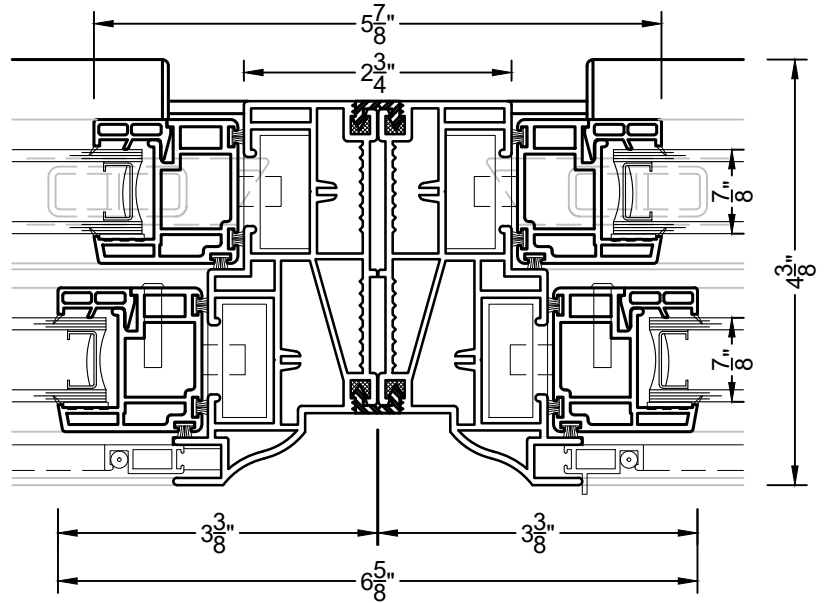

③ 0 DEGREE MULLION
 DH200 & DH200

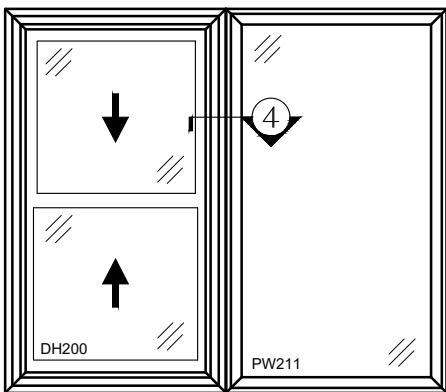

DH200 & PW211

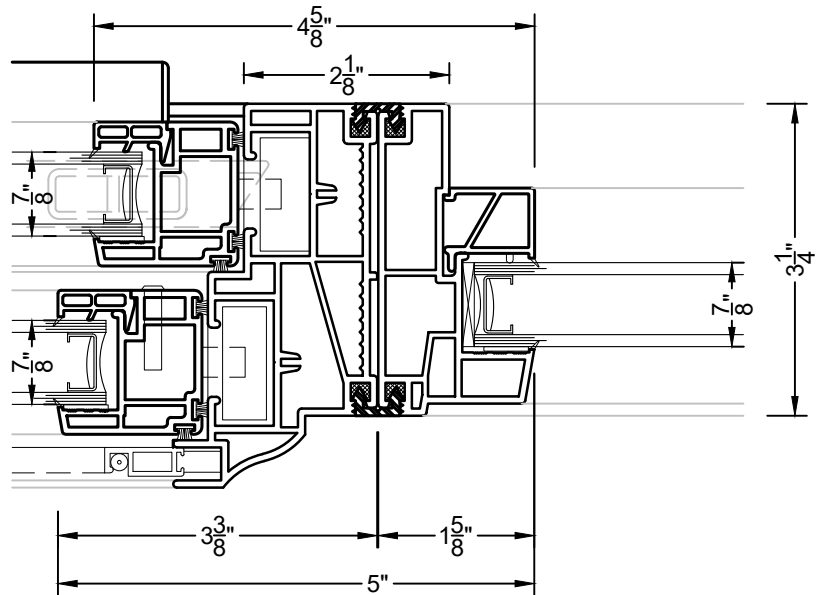

④ 0 DEGREE MULLION
 DH200 & PW211

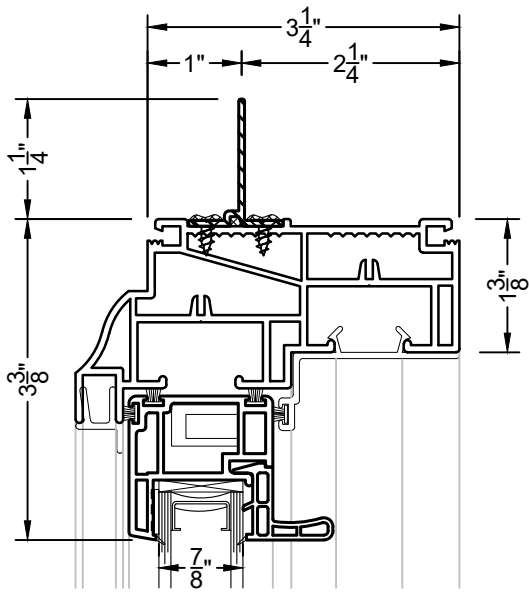

① HEAD - APPLIED NAILING FIN
DH200

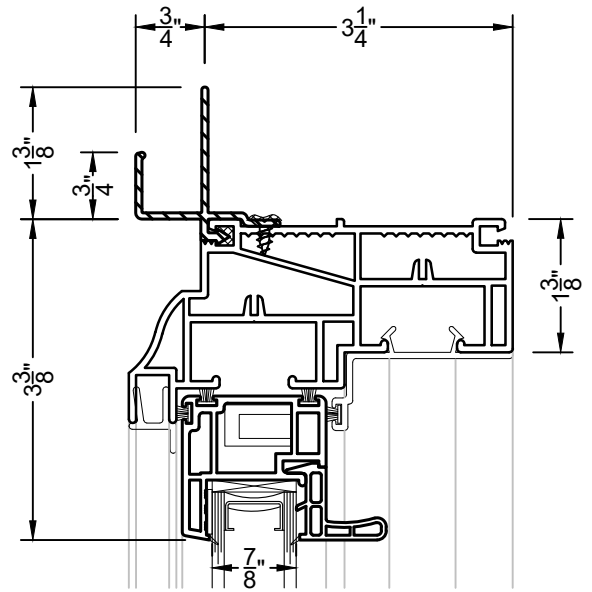

①A HEAD - APPLIED J-CHANNEL
DH200

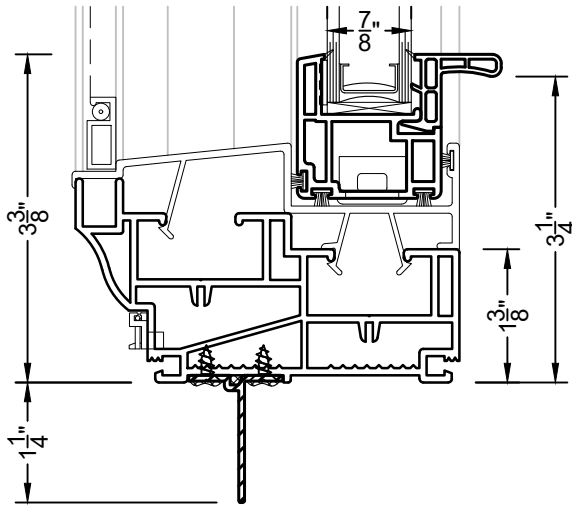

② SILL - APPLIED NAILING FIN
DH200

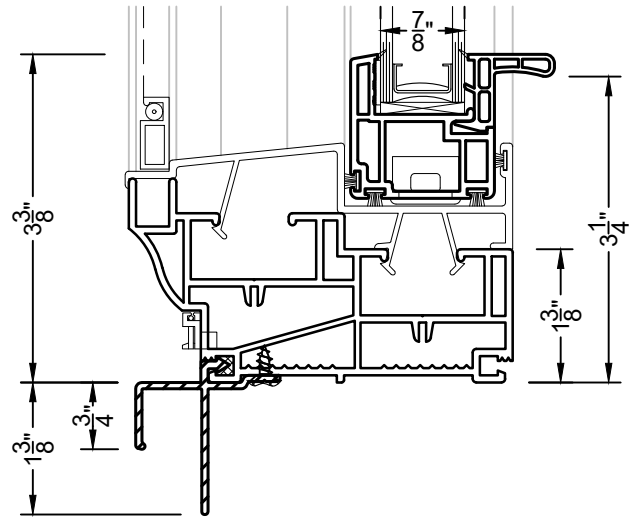

②A SILL - APPLIED J-CHANNEL
DH200

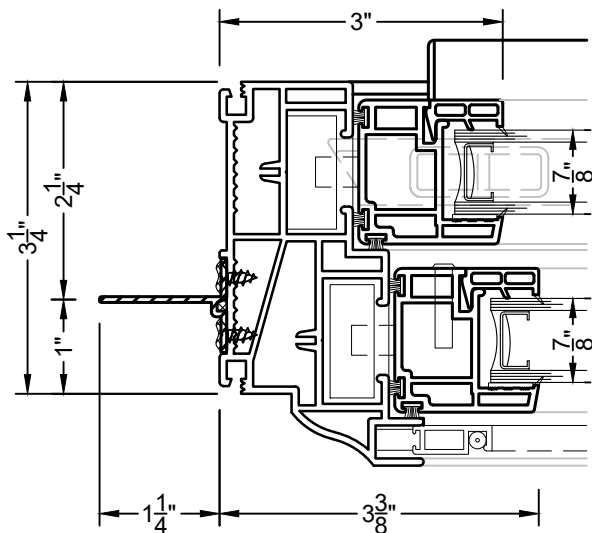

③ JAMB - APPLIED NAILING FIN
DH200

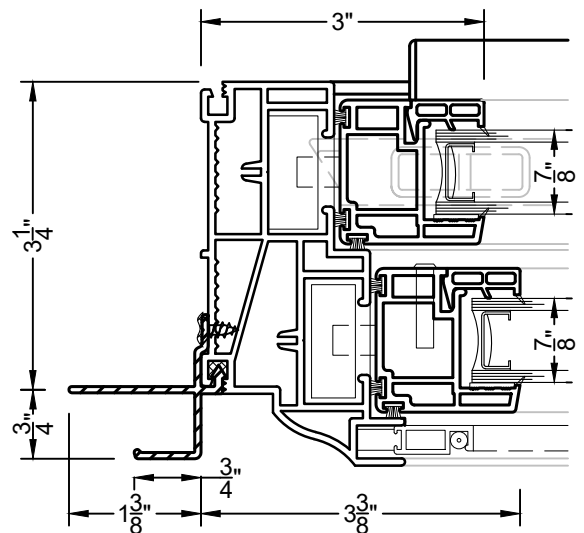

③A JAMB - APPLIED J-CHANNEL
DH200