

SERIES 100 DOUBLE HUNG WINDOW

TEST SIZE W x H	AAMA RATING	AIR INFILTRATION	DESIGN PRESSURE	WATER RESISTANCE	U-VALUE	SHGC	VT
39.5" x 63"	R-PG20	≤0.30 cfm/ft ²	20 psf	3.0 psf	0.24-0.47	0.18-0.59	0.35-0.62



TABLE OF CONTENT

- INTRODUCTION -P1
- SECTION DETAILS -P2
- MULLION -P3-P4

FEATURES

- 3-1/4" FRAME DEPTH
- 7/8" INSULATED GLASS
- SINGLE STRENGTH GLASS
- MEETING RAIL LOCK
- DUAL VENT LOCKS
- TILT SASH WITH TILT LATCH
- CONTINUOUS LIFT HANDLE ON BOTTOM SASH
- SLOPED SILL
- CONSTANT FORCE COIL BALANCE
- JAMB ADJUSTER
- PERIMETER FOAM WRAP

OPTIONAL SELECTIONS

- LOW-E COATING & ARGON FILLED IGU
- CUSTOM FINISH AND CUSTOM COLORS
- SPIRAL BALANCE
- HALF OR FULL SCREEN
- LIMIT STOPS
- INSTALLATION SCREWS
- GRIDS
- OTHER OPTIONAL ACCESSORIES

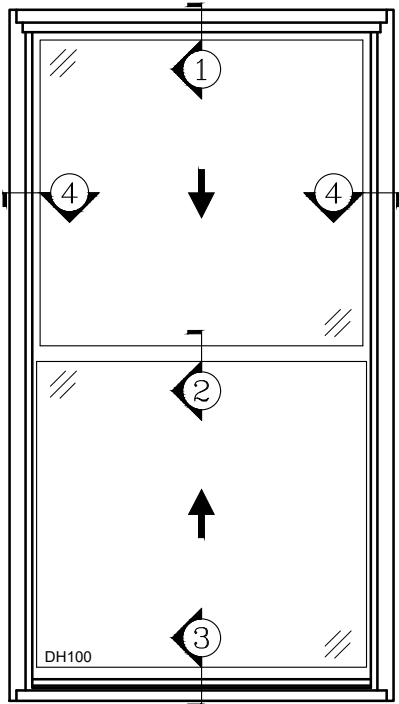

100 DOUBLE HUNG

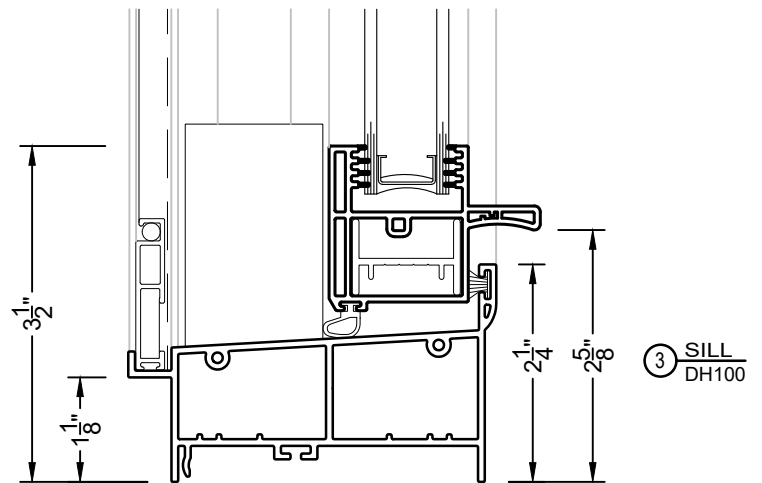
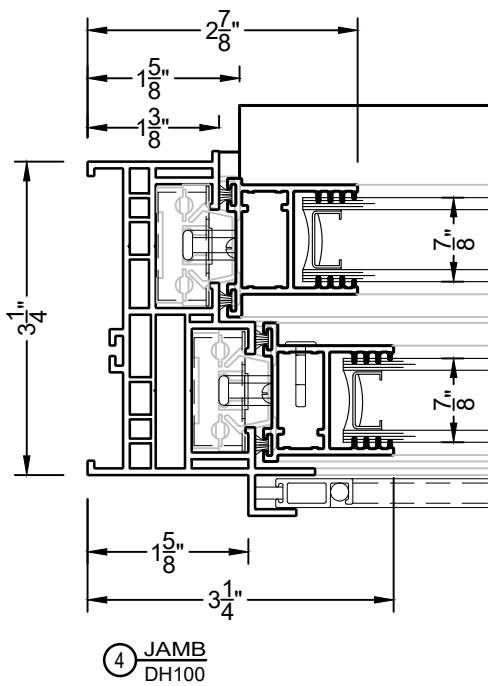
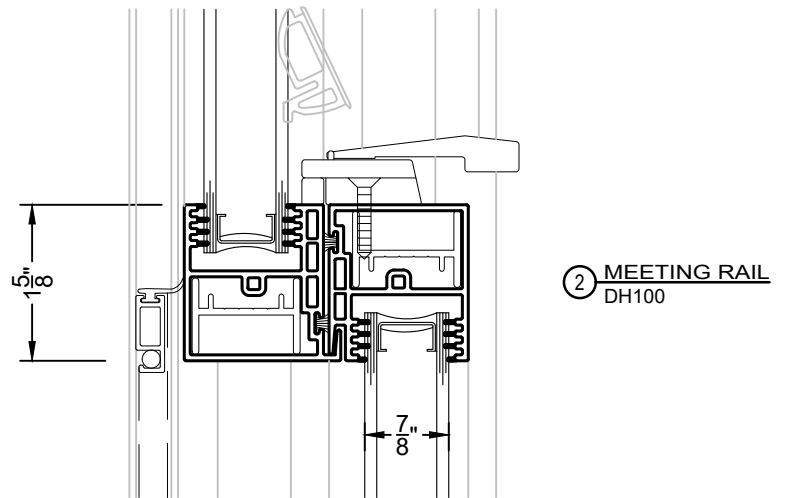
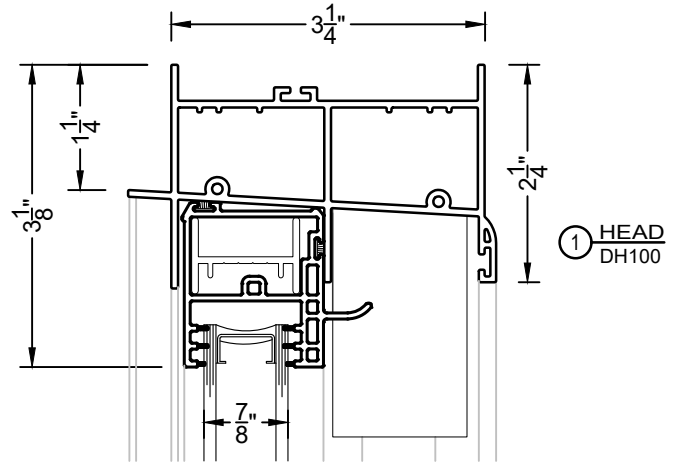

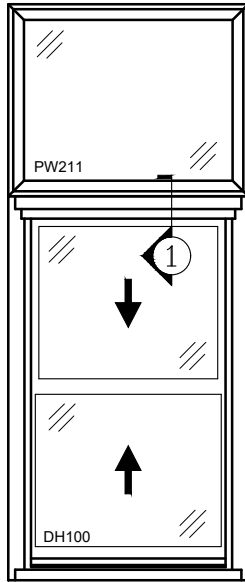

PW211 OVER DH100

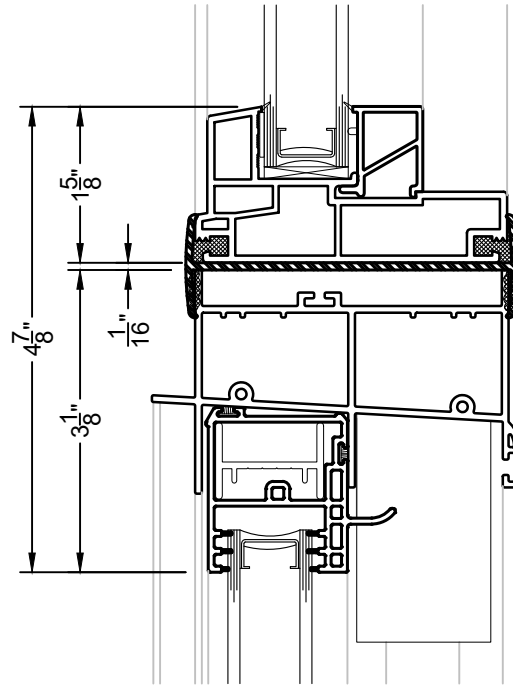

① H-MULLION
 PW211 OVER DH100

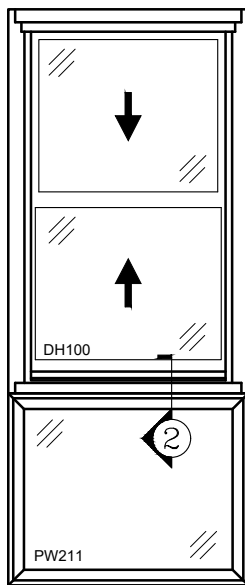

DH100 OVER PW211

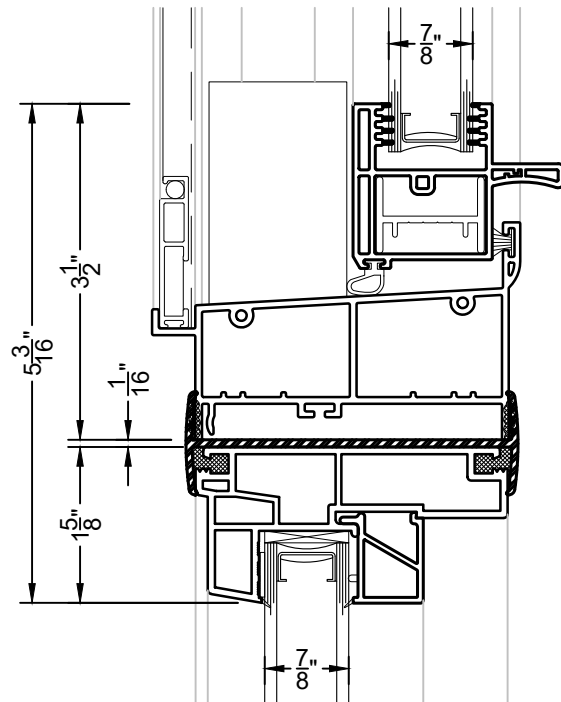

② H-MULLION
 DH100 OVER PW211

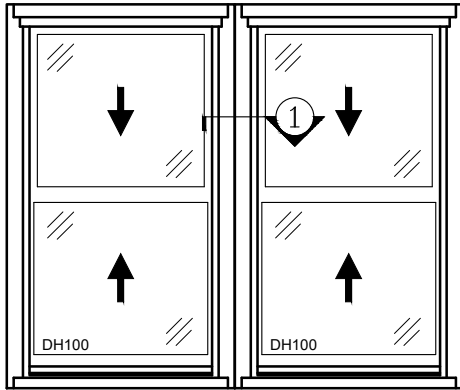

DH100 & DH100

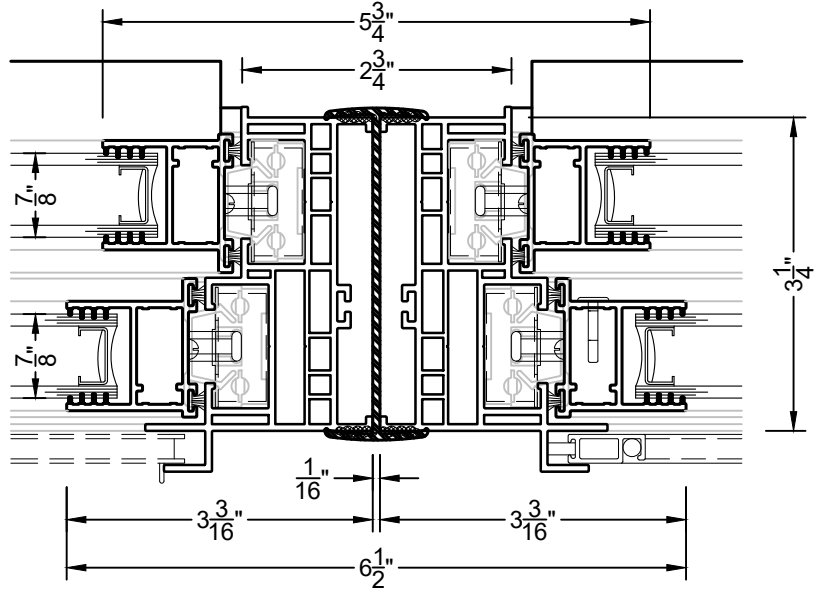

① H-MULLION
 DH100 & DH100

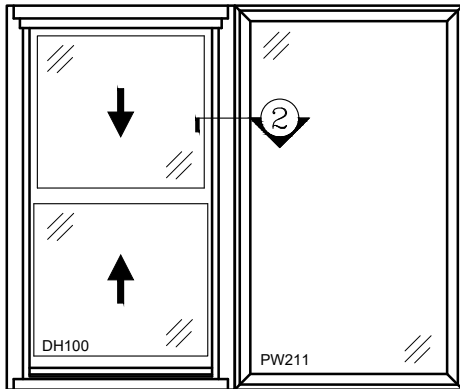

DH100 & PW211

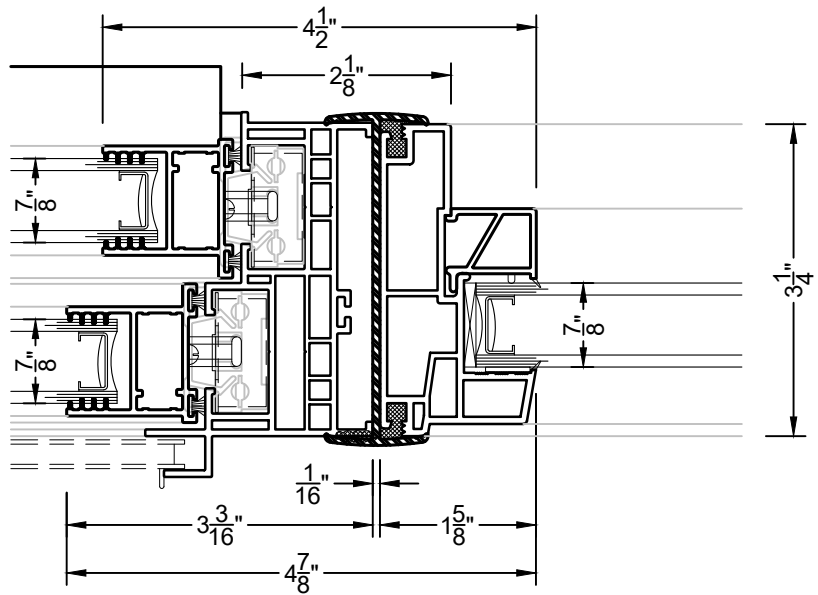

② H-MULLION
 DH100 & PW211